

Delta Mixer Se-04/Se-08

Our proprietary technology "Delta balance" prevents Mixer be moved around during operation. The user-friendly mixer that offers excellent stirring and stability that developed by customer's request.

Stirring Microtube and Well plate "Micro mixer E-36" --> P.061 Crusher "Beads crusher" series --> P.086-087



Se-04

Se-08

Well-balanced Mixer that not be moved around thanks to Delta balance.

We developed three legs and triangle body to realize for customer's request "Desired a mixer that not be move around". We got the result that Mixer was not moved around on slippery plane and slope that were painted with oil.



"Soft touch switch for stirring" and "Continuous stirring switched [Se-08]"

Between Touch switch "turns on/off when the head is lightly pressed and Continuous stirring can be switched. Touch switch was designed for optimal sensitivity to start with a light touching.



Features

- "Delta balance" prevents Mixer be moved around during operation.
- Hand-held stirring and "Miracle head" holds Microtubes
- Operation mode by touch switch. Stirring strength adjustment [Se-08]

Applications

- Mixing-stirring of samples and reagents
- Promotion of various reactions by stirring
- Crushing of fungal etc. with beads.

Microtubes can be fixed to "Miracle Head"

Our original Miracle Head enables smoothly hand-held stirring of 15ml and 50ml Centrifuge tubes and also Microtubes on the center of head. Up to 30ml out of 50ml in Centrifuge tubes can be stirred for sure. Microtubes can be fixed to the periphery of Miracle Head. Useful for long-time stirring.



Dimensions

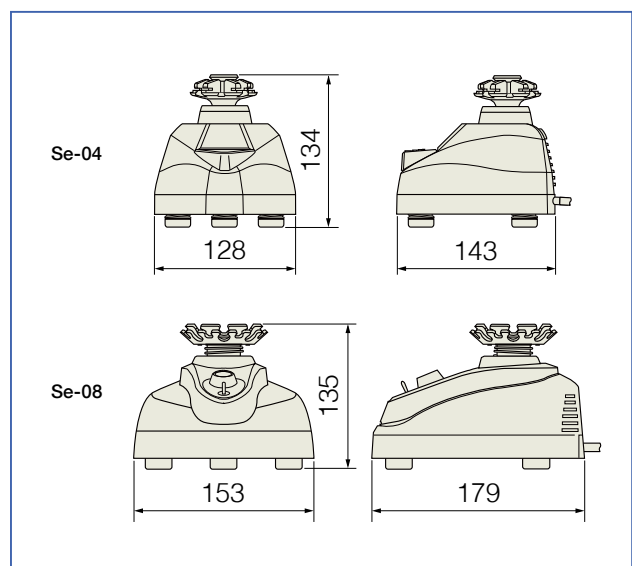

| Model | Se-04 | Se-08 |
|------------------------|--|---|
| Stirring motion | Horizontal eccentric | |
| Vibration speed (*1) | Approx. 2800r/min (Fixed) | Up to 2800r/min (Strength adjustment) |
| Operation mode | Continuously | Switching Touching mode/Continuously |
| Capacity | Hand-held stirring Microtubes and 50ml in Centrifuge tubes (*2) Stirring with Microtubes fixed Se-04: 4pcs x 0.5ml + 4pcs x 1.5/2.0ml Se-08: 8pcs x 0.5ml + 8pcs x 1.5/2.0ml | |
| Ambient temperature | 5°C to 35°C | |
| Dimensions (W x D x H) | 128 x 143 x 134mm (Miracle Head included) | 153 x 179 x 135mm (Miracle Head included) |
| Weight | Approx. 2kg (Miracle Head included) | Approx. 3kg (Miracle Head included) |
| Power supply | AC100V/0.5A | |
| Standard accessories | 1 x Miracle Head 04 | 1 x Miracle Head 08 |

(*1) The value at 50Hz. The value at 60Hz is under 3300r/min in Se-08.
(*2) Up to 30ml out of 50ml in Centrifuge tubes can be stirred for sure.